



Custom Solutions Bulletin

Industry: Wastewater Treatment

Application: High Impact Washing

Product Descriptions: 1" NCS (Stubby) 1007M in 316 SS

Situation: At a municipal wastewater treatment facility, a screw conveyor moves dewatered sludge from the centrifuge to a conveyor belt. The sludge, which is organic material settled out of the wastewater during primary treatment, is then transported for final disposal. Residual water from the sludge is drained from the screw conveyor. The drainage passes and changes direction through a tee where dissolved solids can collect on the pipe wall. It is critical that these solids are removed before they harden, which could lead to a blockage in the drainpipe.

BETE's solution: BETE Applications Engineering was contacted by a consulting engineering firm that had proposed spray nozzles as a solution. Nozzles would be inserted through two locations on the tee, spraying effluent water in order to wash away the sludge before it could harden. Because space is limited inside the 6" tee, the nozzles would need to be low profile, but still large enough to deliver enough force to wash away the sludge. The BETE NCS (stubby) series is ideal in this situation, because it is as compact as a pipe plug, yet performs like a full size nozzle. Two pieces of the 1" NCS1007M were specified to operate at 60 psi (4.1 bar) and flow 19.2 gpm (72.7 l/min) each.

Technical Questions?

Please contact:
Applications Engineering
(appeng@bete.com)
413-772-0846
App#080324

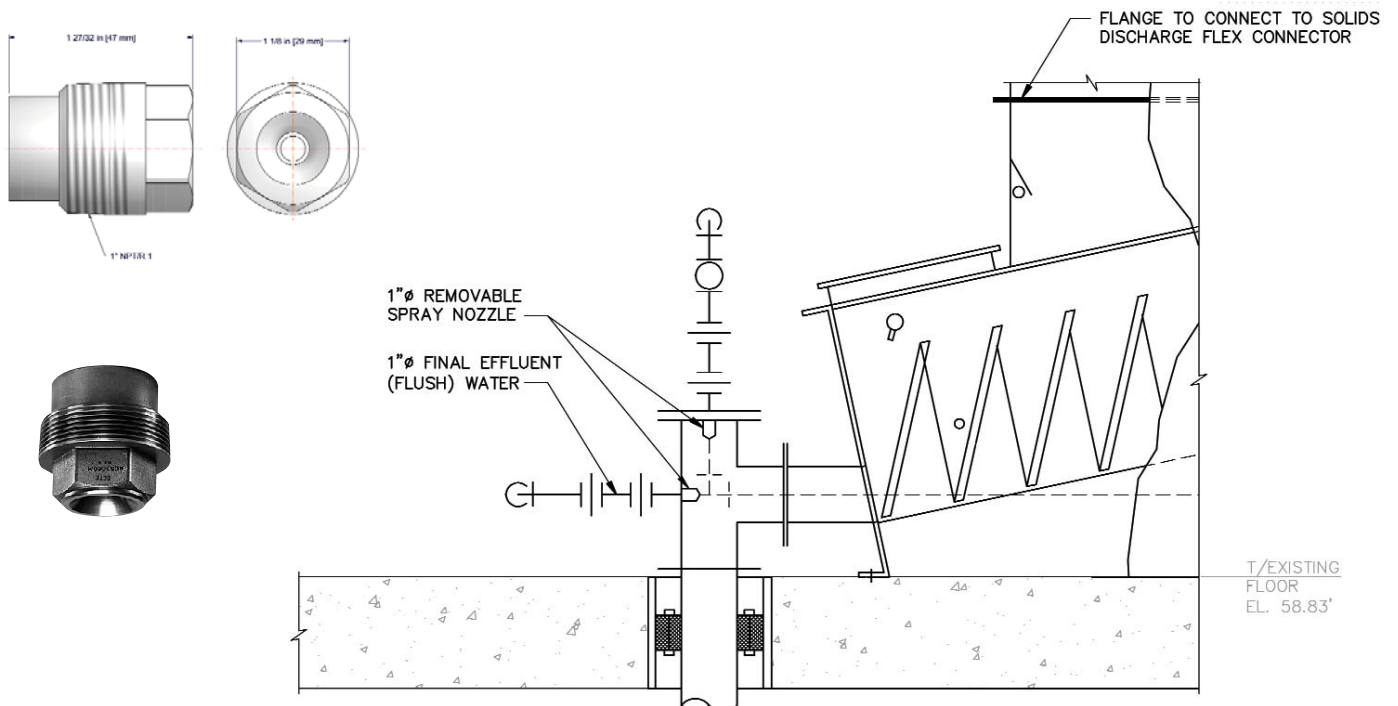

App#080324