

# CUSTOM LANCE

## APPLICATION INFORMATION REQUEST FORM

All completed forms should be emailed back to: [sysfab@bete.com](mailto:sysfab@bete.com)  
 Please fill out the following form as completely as possible to assist in the nozzle selection process.

### Contact Information:

Date:	Name:
Telephone:	Company:
Fax:	Address:
Email:	Job/Reference #:
Industry:	Process Lance is Used in:

### Codes:

Design Code/Registration: <input type="checkbox"/> ASME B31.3 <input type="checkbox"/> PED <input type="checkbox"/> CRN <input type="checkbox"/> None <input type="checkbox"/> Other _____			
Design Vessel Pressure:	<input type="checkbox"/> psi <input type="checkbox"/> bar	Design Vessel Temperature:	<input type="checkbox"/> °F <input type="checkbox"/> °C
Design Liquid Pressure:	<input type="checkbox"/> psi <input type="checkbox"/> bar	Design Liquid Temperature:	<input type="checkbox"/> °F <input type="checkbox"/> °C
Corrosion Allowance:	<input type="checkbox"/> in <input type="checkbox"/> mm	Corrosion:	<input type="checkbox"/> MR0175 <input type="checkbox"/> MR0103 <input type="checkbox"/> A262 Practice

### Additional Testing/QC Requirements:

NDE Type		Extent of NDE and on what components
Dye Penetrant	<input type="checkbox"/> Yes <input type="checkbox"/> No	
Radiographic Test	<input type="checkbox"/> Yes <input type="checkbox"/> No	
Ultrasonic Test	<input type="checkbox"/> Yes <input type="checkbox"/> No	
Hardness	<input type="checkbox"/> Yes <input type="checkbox"/> No	
Hydrotest	<input type="checkbox"/> Yes <input type="checkbox"/> No	
Other (specify)		

Material Test Reports	<input type="checkbox"/> Yes <input type="checkbox"/> No	Weld Procedure Approval	<input type="checkbox"/> Yes <input type="checkbox"/> No
-----------------------	--	-------------------------	--

### Spray Nozzle Selection:

What Liquid is being Sprayed:		Specific Gravity:	
Liquid Flow Rate:	<input type="checkbox"/> GPM <input type="checkbox"/> L/min	Liquid Pressure Drop:	<input type="checkbox"/> psi <input type="checkbox"/> bar
<input type="checkbox"/> Air/ <input type="checkbox"/> Steam Flow Rate:	<input type="checkbox"/> SCFM <input type="checkbox"/> m3/hr	Air/Steam Pressure Drop:	<input type="checkbox"/> psi <input type="checkbox"/> bar
Spray Pattern: <input type="checkbox"/> Full Cone <input type="checkbox"/> Hollow Cone <input type="checkbox"/> Fan		Nozzle Spray Angle:	
Nozzle Material:		Nozzle Connection Size:	
Specify any erosive or corrosive conditions present:		Nozzle Connection Style:	
Nozzle Model (if known):		Is a tack weld required for threaded nozzles?	

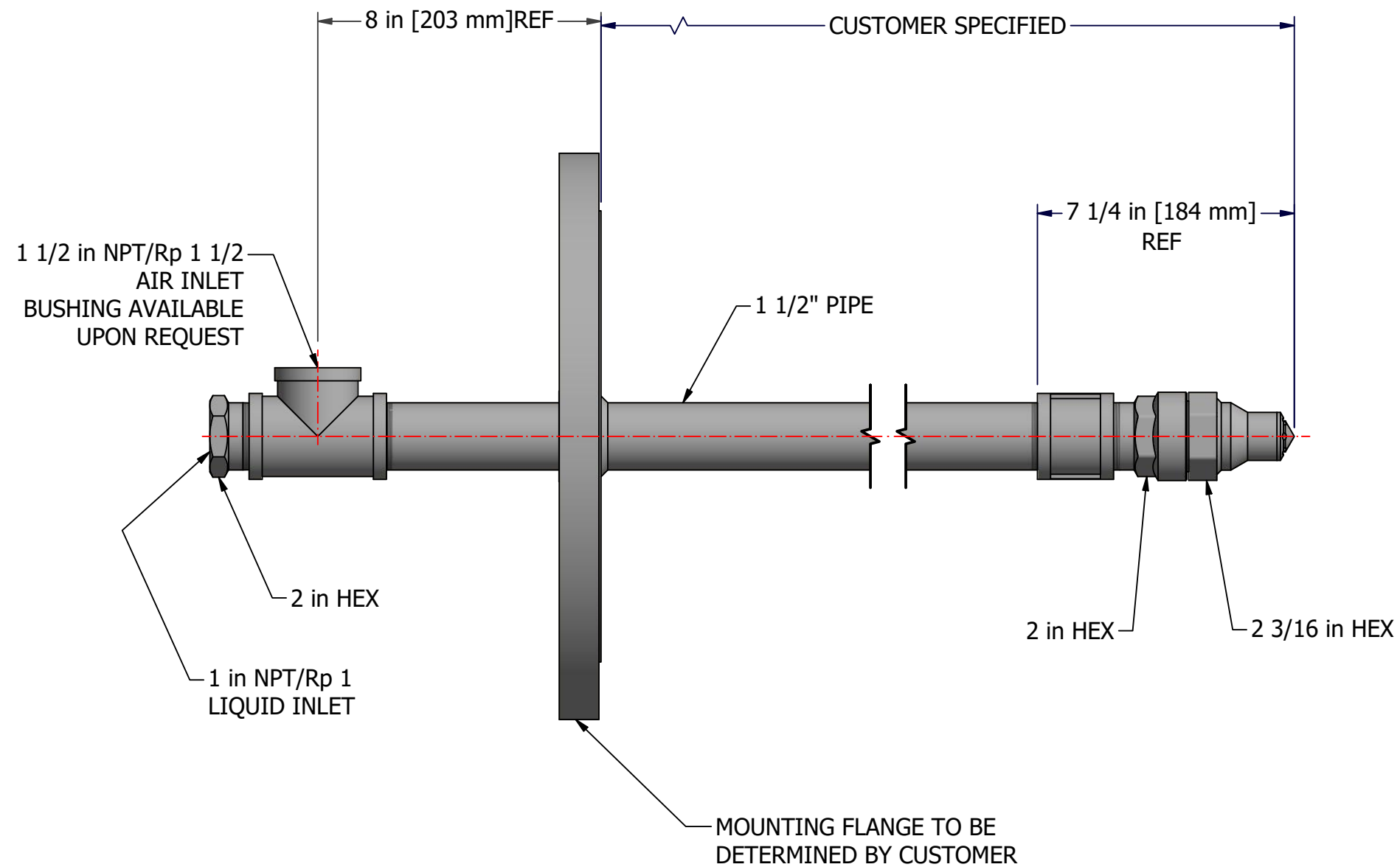

Ø2 3/4 in [70 mm]  
CLEARANCE DIAMETER  
REF

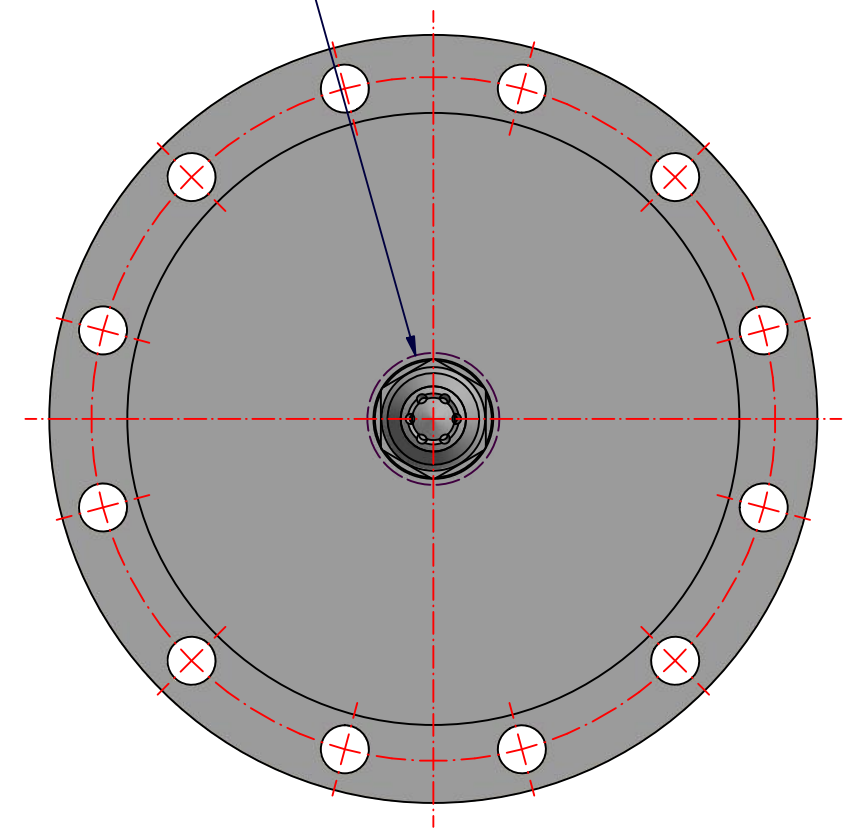

**NOTES**

- 1. STANDARD MATERIALS:  
TIP & COVER - COBALT ALLOY 6  
O-RING (LOCATED IN TEE) - VITON  
REMAINING COMPONENTS - 316 STAINLESS STEEL

\* ALTERNATE MATERIALS ARE AVAILABLE UPON REQUEST

B	4/5/2021	JF		34829
A	04/10/2012	KG	JF	26394
REV	DATE	BY	CHECKED	DCR

3RD ANGLE PROJECTION UNLESS OTHERWISE NOTED, REMOVE ALL BURRS AND SHARP EDGES  
THIS PRINT CONTAINS PROPRIETARY INFORMATION WHICH MUST NOT BE USED FOR COMPETITIVE PURPOSES OR IN ANY WAY DETRIMENTAL TO BETE FOG NOZZLE INC. PRINT MUST BE RETURNED UPON REQUEST © BETE FOG NOZZLE, INC.

TOLERANCES: (EXCEPT AS NOTED)  
MACHINED DIMENSIONS: ANGLES.....±1/2°  
FRACTIONAL.....±1/32°  
TWO PLACE DECIMAL.....±.01°  
THREE PLACE DECIMAL.....±.005°  
CAST DIMENSIONS: UP TO 1".....±.010°  
FOR EACH INCH AFTER ADD ±.003° PER IN.  
METRIC: WHOLE NUMBER.....±1mm  
ONE PLACE DECIMAL.....±.4mm  
TWO PLACE DECIMAL.....±.14mm

<b>BETE FOG NOZZLE, INC.</b>			
50 GREENFIELD STREET GREENFIELD, MASSACHUSETTS 01301			
1 1/2" SA XXX-B-10			
GENERAL ARRANGEMENT DRAWING			
SCALE: 1:4	DRAWN: SL DATE: 3/15/2012	CHECKED: JF DATE: 3/26/2012	REV B
DRAWING NUMBER: LN - 65450			