

HydroWhirl® Stinger



(HWS2) Reactionary Force Slotted Spray Nozzle



DESIGN FEATURES

- Patent-pending no-weld design eliminates weak points and uneven surfaces
- Bearing assembly is centered within the spray head for improved balance and spray propagation
- Compact size with industry-leading flow rates fits 3/4"-2" tri-clamp openings
- Better spray uniformity can be maintained at lower pressures
- Unique patent-pending pipe thread technology flushes to reduce contamination and bacteria growth
- Zirconia ceramic bearings for long service life and extreme chemical resistance*
- 32Ra surface finish ideal for sanitary applications

SPRAY CHARACTERISTICS

- Vigorous spray action
- Optimum cleaning performance @ 40psi
- Spray Angles:** Complete 360° spray coverage
- Flow Rates:** 1.1 to 102 GPM
- Max Temperature:** 200°F/93°C
- Filtration:**
 - Line strainer with a mesh size 75 microns/200 mesh for HWS2-4 and smaller
 - Line strainer with a mesh size 100 microns/150 mesh for HWS2-7.5 and larger

*Note: Rated for use with liquids only. Compressed air, steam, or other gasses should never be run through the nozzle as the bearings are lubricated by the process media.

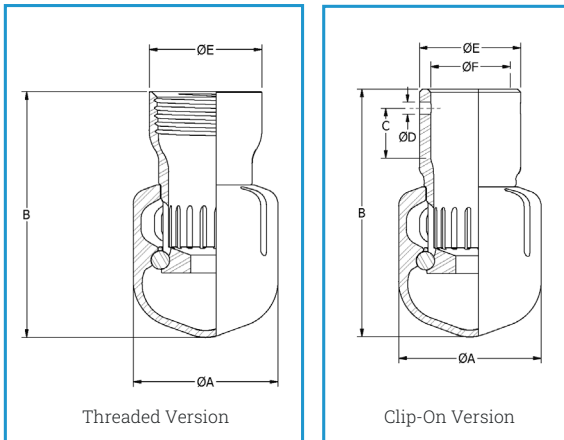

DIMENSIONS IN INCHES (CLIP-ON)

Tube Size	A	B	C	D	E	F	Weight (oz)	Min Tank Entry Dia
1"	1.85	3.40	0.85	0.156	1.32	1.00	12	1.85
3/4"	1.35	2.84	0.49	0.086	1.06	0.75	7	1.35
1/2"	0.85	1.91	0.50	0.086	0.84	0.50	3	1.19
3/8"	0.60	1.38	0.34	0.086	0.56	0.38	0.8	0.90

DIMENSIONS IN INCHES (THREADED)

Pipe Size	A	B	E	Weight (oz)	Min Tank Entry Dia
1"	1.85	3.13	1.44	10.5	1.85
3/4"	1.35	2.75	1.15	5.2	1.35
1/2"	1.35	2.38	0.95	4.7	1.35
3/8"	0.85	1.81	0.75	1.4	0.85
1/8"	0.60	1.25	0.50	1	0.60

HYDROWHIRL® STINGER FLOW RATES

Materials: 316L Stainless Steel Body, Ceramic Bearings

Female Connection Type	Nozzle Number	Spray Angles	Flow Rate (gpm) @ Differential Pressure (psi)						Maximum Free Passage	Coverage Dia @ 40 psi
			10	20	30	40	50	60		
			psi	psi	psi	psi	psi	psi		
1/8" FNPT, BSP 3/8" Tube Clip-On	HWS2-2.1	360°	1.09	1.51	1.83	2.10	2.33	2.54	.025	2
	HWS2-4		2.05	2.86	3.48	4.00	4.46	4.87	.039	7
	HWS2-7.5		3.84	5.37	6.53	7.50	8.35	9.12	.063	7
3/8" FNPT, BSP 1/2" Tube Clip-On	HWS2-10	360°	4.94	7.03	8.64	10.0	11.2	12.3	.024	8
	HWS2-12		6.22	8.64	10.5	12.0	13.3	14.5	.039	10
	HWS2-17		8.59	12.1	14.8	17.0	19.0	20.8	.079	10
1/2" FNPT, BSP	HWS2-20	360°	10.2	14.3	17.4	20.0	22.3	24.3	.039	10
	HWS2-26		12.9	18.3	22.5	26.0	29.1	31.9	.064	10
3/4" FNPT, BSP 3/4" Tube Clip-On	HWS2-20	360°	10.2	14.3	17.4	20.0	22.3	24.3	.039	10
	HWS2-26		12.9	18.3	22.5	26.0	29.1	31.9	.064	10
1" FNPT, BSP 1" Tube Clip-On	HWS2-33	360°	16.6	23.4	28.6	33.0	36.8	40.3	.031	11
	HWS2-55		27.6	39.0	47.7	55.0	61.5	67.3	.064	12
	HWS2-66		33.4	46.9	57.3	66.0	73.7	80.6	.094	12
	HWS2-84		43.2	60.2	73.2	84.0	93.5	102	.125	12

Flow rates represent threaded connections with a 360° spray angle.
Flow rates may vary for other connection types and spray angles.