

Industry: Chemical Processing

Application: Toluene Injection

Product Description: Special XA Lance Assembly

Situation: A large chemical processor called BETE in need of a special XA lance to inject toluene into a process stream. The customer had an existing 36" duct with a 4" pipe entering it at a 45 degree angle. The BETE XA lance would need to enter through the 4" pipe yet spray parallel with the 36" duct.

BETE's solution: BETE Engineers designed a special BETE XA body that would spray in a direction 45 degrees offset from the inlet pipes. This would allow the specified XAPR250 setup to spray co-currently with the process gas flowing through the duct. The body was incorporated into a lance assembly, also designed by BETE, providing a convenient solution for the customer.

Technical Questions?

Please contact:
Applications Engineering
(appeng@bete.com)
413-772-0846
App#061913

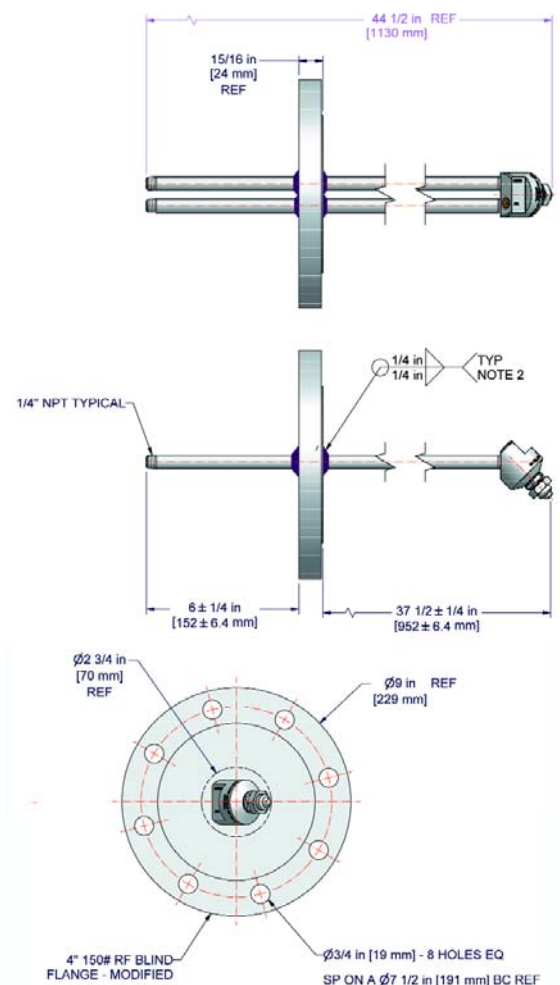
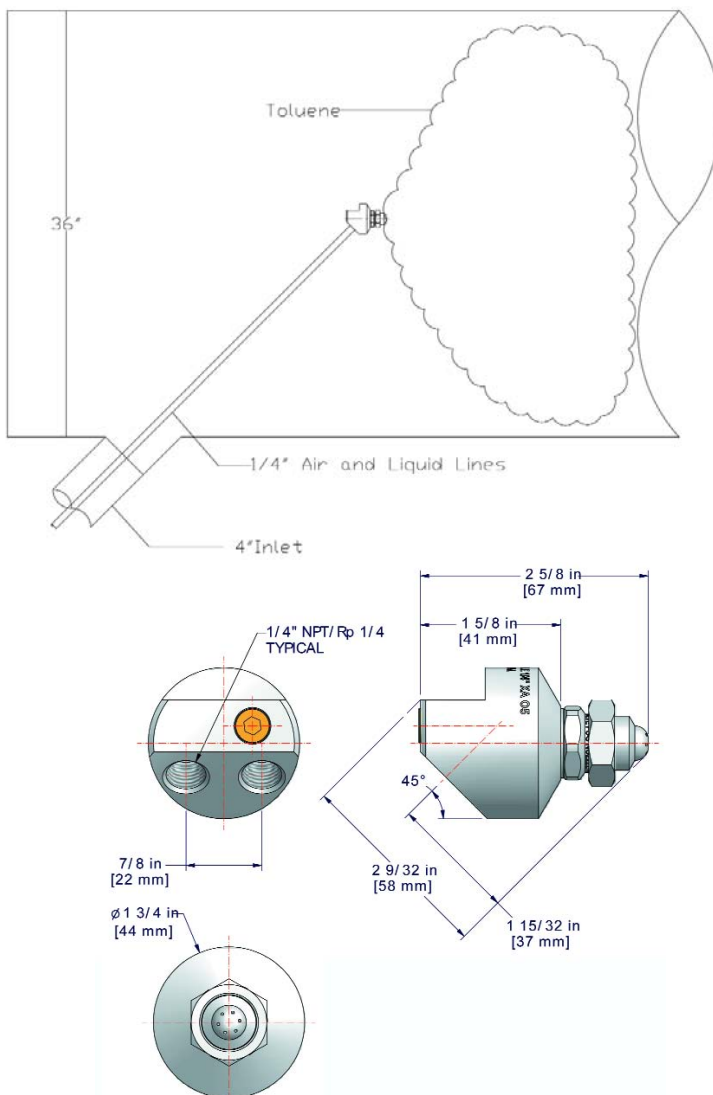

App#061913